

Functional principle, sealing theory

A variety of factors surrounding the sealing system is responsible for the reliable functioning of the shaft seal. The whole sealing system, comprised of the shaft seal, shaft, housing, medium, environmental and operating conditions, determines the functioning and durability of the seal.

The shaft seal performs 2 sealing tasks:

- The static sealing between the housing bore and the outer diameter of the seal; which simultaneously guarantees a secure and tight fit of the seal in the housing.
- The dynamic sealing between the sealing edge of the shaft seal and the shaft surface. (When the shaft stops, the sealing is also static.)

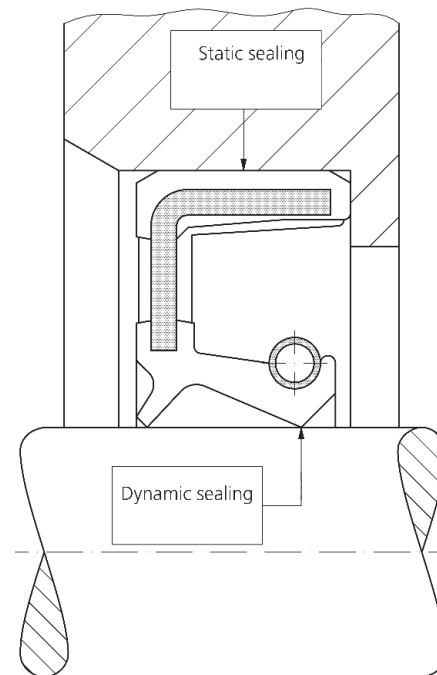

Static sealing

The static sealing between the housing bore and the outer diameter of the shaft seal is achieved by an oversize of the outer diameter of the seal. (see tables + characteristics)

The prescribed fitting and lead-in chamfers determine the design of the seal and the installation space in such a way that a good compromise between simple installation and static sealing is obtained.

The press fit allowance is the dimension by which the outer diameter of the shaft seal is larger than the nominal dimension of the housing bore.

Outer-Ø D	Permitted diameter difference (out-of-roundness) for outer diameter D
up to 50	0.25
over 50 up to 80	0.35
over 80 up to 120	0.5
over 120 up to 180	0.65
over 180 up to 300	0.8
over 300 up to 500	1.0

The diameter difference ($D_{max} - D_{min}$) is obtained from 3 or more measurements distributed equally on the circumference.

Press fit allowance of the shaft seal outer diameter

Outer-Ø D	Types acc. to DIN type A	Types acc. to DIN type A + ribbing	Types acc. to DIN type B & C
	Elastomer outer shell, smooth	Elastomer outer shell, ribbed	Outer shell metal
up to 50	+0.30	+0,40	+0.20
	+0.15	+0,20	+0.10
over 50 up to 80	+0.35	+0,45	+0.23
	+0.20	+0,25	+0.13
over 80 up to 120	+0.35	+0,45	+0.25
	+0.20	+0,25	+0.15
over 120 up to 180	+0.45	+0,55	+0.28
	+0.25	+0,30	+0.18
over 180 up to 300	+0.45	+0,55	+0.30
	+0.25	+0,30	+0.20
over 300 bis 500	+0.55	+0,65	+0.35
	+0.30	+0,35	+0.23

Versions of outer diameters

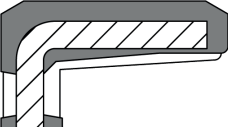
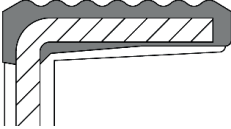
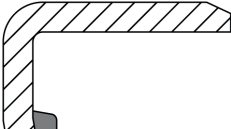
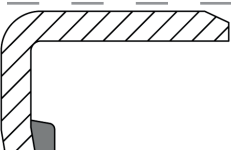
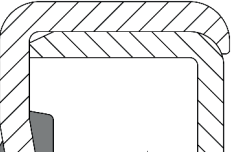
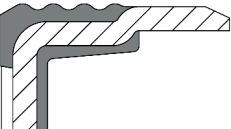
Sketch	Design	Characteristics of the outer diameter versions A, B, C
	Rubber-covered outer diameter, smooth (as in type A DIN 3760)	high safety of static sealing, for housings with high thermal expansion, e.g., light metal housings, for split housings, for housings with increased surface roughness, for pressure applications, for sealing thin-bodied or gaseous media, no risk of frictional corrosion
	Rubber-covered outer diameter, ribbed (as in type A , DIN 3760 + wave profile)	In addition to the properties of the smooth version: best static sealing on the outer diameter due to higher press fit allowance, for ease of installation, spring back and skew of the seal after press-in is avoided
	Metal outer diameter (as in type B , DIN 3761)	very tight and exact fit in the housing due to metal/metal press fit, care should be taken in connection with light metal housings, housings with increased surface roughness and pressure applications: sealing aids on outer diameter can be used, if necessary.
	Metal outer diameter, lacquered (as in type B , DIN 3761)	
	Metal outer diameter + reinforcing cap (as in type C , DIN 3761)	insensitive to rough or wrong installation, larger sizes provide more rigidity
	Partially rubber-covered outer diameter, (combination of type A and B)	combines the very good static sealing of type A with the tight fit in the housing of type B

Dynamic sealing

When the shaft rotates, a hydrodynamic sealing mechanism is established in the contact zone between the sealing edge and the shaft. The geometry of the sealing lip, the sealing lip material and the surface structure of the shaft are essential for the sealing mechanism.

Important design features of the sealing lip are:

- front-side sealing lip angle
steep angle at the medium side
- bottom-side sealing lip angle
flat angle at the air side
- Length and thickness of the sealing lip
influence the flexibility of the sealing lip, from suitability for true running and offset deviation (long, flat profile) to pressure loadable sealing lips (short, high profile)
- Spring position
Slight axial inside displacement of the spring action line in relation to the plane of the sealing edge (see figure description shaft seal)
- Interference of sealing lip
The inside diameter of the seal before installation is smaller than the outer diameter of the shaft. The sealing lip is stretched accordingly during installation.
- Radial force of the sealing lip
The resilience of the sealing lip resulting when the sealing lip is stretched during installation acts as ring-shaped pressure on the shaft surface. This radial force is composed of both the tensile and bending stresses in the elastomer and the expansion of the tension spring.

With increasing rotation of the shaft, from the state of static friction to mixed friction, a hydrodynamic sliding state is created. This causes the sealing edge to float and a very thin sealing gap filled with lubricant (medium) is created. The lubricant in the sealing gap performs the essential task of lubricating and cooling the sealing area. The lubricant that fills the sealing gap is returned to the system by a micro-pump action and does not escape to the air side of the seal as leakage.

The micro-pump effect is produced by the non-symmetrical distribution of the contact pressure in the sealing gap, resulting from the different sealing lip angles and the radial force of the seal.

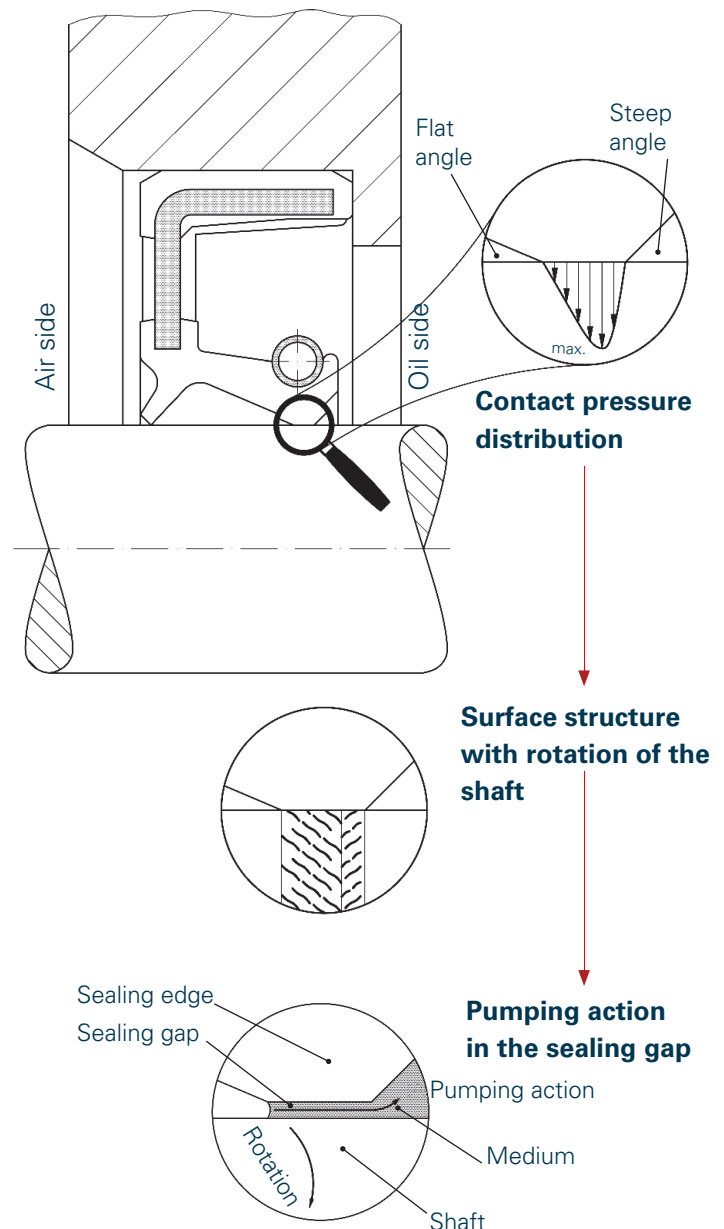

At the start of rotation the elastomer in the contact zone of the sealing edge is deformed in the direction of rotation. A surface structure of many small depressions and protrusions (known as microasperities) running at a slant in the direction of rotation is created. The medium circulating in the sealing gap with the shaft is deflected by these structures. As a result of the non-symmetrical distribution of the contact pressure more structures face towards the medium side than to the air side, causing a total pumping effect in the direction of the medium side.

Hydrodynamic sealing aids, helix

As a special design, shaft seals can be provided with a so called helix on the bottom side of the sealing lip. When the medium from under the sealing edge reaches the bottom side, the helix with the rotation of the shaft assists the return feeding and thus the hydrodynamic sealing effect.

Running diagonally to the sealing lip, elevated helix ribs lead any medium which may have reached the bottom side to the sealing edge and under it back to the space to be sealed.

Shaft seals with this helix create an increased pumping effect and can, therefore, still guarantee the required sealing effect under aggravated operating conditions such as slightly damaged shaft surfaces or increased eccentricity.

The various helix types are divided into single helix and bidirectional helix.

Shaft seals with a single helix are suitable for only one rotational direction of the shaft, and are referred to as clockwise or anticlockwise.

Shaft seals with a bidirectional helix are suitable for shafts with alternating rotational direction.

